



# Parts and Operators Manual

## STM Super Flail 30" Electric Clutch Model

Issue 4 - December 2018

**S T M Company Limited**

Tel: 01789 488450 • Fax: 01789 488032 • Email: [sales@st-mach.com](mailto:sales@st-mach.com) • [www.st-mach.com](http://www.st-mach.com)

## STM Super Flail 30"

### **BELT ADJUSTMENTS**

To adjust either the engine-driven belt or gearbox drive belt, remove the guard (4)

#### Engine-driven belt

*Electric Clutch models:* tighten nut to keep washer level with face of endplate [see figure 2]

**Do not over-tension!**

#### Gearbox belt

Slacken bearing lockbolts (58) and corresponding lockbolts on bottom bearing.

Adjust twin pulley by means of screw (97). Do not over-tighten!

Tighten all bearing bolts and locknuts and re-fit guard.

#### Twin rotor drive belts

Remove guard (7), slacken locknut (11) in centre of flat pulley (9), and pull up by hand. Tighten locknut. (See illustration below). **Do not over-tension belts!**

fig 1

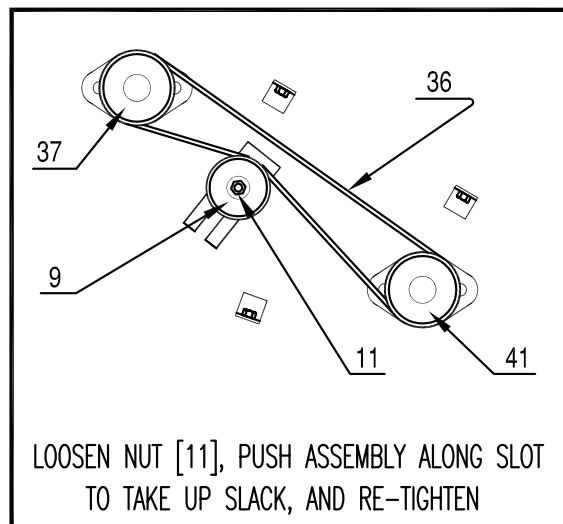

### **BELT REPLACEMENT**

#### Engine-driven belt

##### **Electric Clutch models:**

Remove guard (4): Loosen off Lock nut and washer "A" - as shown in fig 2 below.

This slackens off the electric clutch pre-tension mechanism.

Replace belt.

Re-tension belt with Lock nut and washer "B" and lock up nut and washer "A" - ref fig 2 below.

## STM Super Flail 30"

### **BELT REPLACEMENT** *Electric Clutch models: [continued]*

fig 2

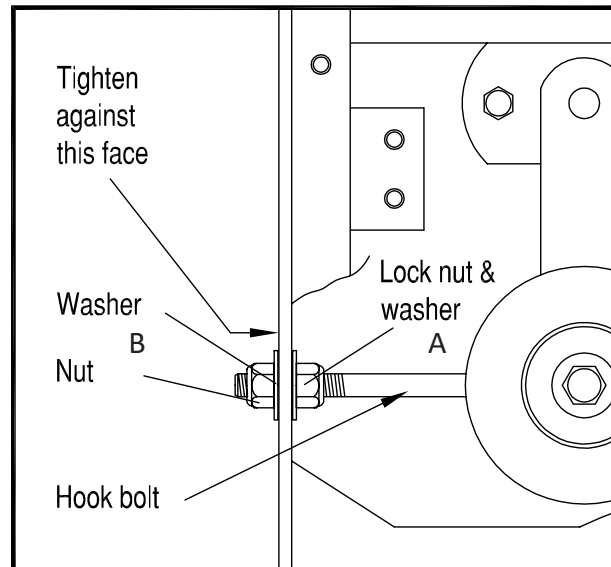

*Illustration for pre-tensioning pulley on Electric Clutch models*

### **BELT REPLACEMENT** *[Engine driven belt]....continued*

#### Rotor belts

*Remove guard (7), slacken adjuster pulley (9) to bottom of slide and remove belts.*

**ALWAYS REPLACE THESE BELTS IN PAIRS.**

*Adjust belt tension as above and refit guard.*

### **LUBRICATION**

#### Gearbox

*Remove level plug and fill through plug hole with gear oil EP80/140*

#### Bearings

*Nos 95 (2 off) and 3 (3 off) - give 2 or 3 shots with a hand-held grease gun every 500 hours.*

**DO NOT OVER-GREASE**

Caster wheels: *(swivel and axle nipples) - lubricate every 12-14 hours.*



## STM Super Flail 30"

Drawing ref	Part No.	Description
1	10713	Belt (Gearbox) B58
2	486045	Pulley
3	10003	Bearing LFTC25A
4	10004	Guard
5	10226	Guard
6	10225	Guard
7	10007	Guard
8	10470	Adjuster block
9	10009	Pulley
10	43660	Boss
11	PL	Bolt M10 x 100
12	482764	Pulley
13	PL	Spring washer - 8mm
14	PL	Hex nut - 8mm
15	PL	Bolt
16	PL	Nyloc nut
17	10013	Gearbox
18	461023	Caster assy complete
19	04066-01	Quick pin
20	43037-01	1/2" Spacer (Caster yoke)
21	48100-01	Bronze bearing
22	48114-04	Grease nipple
23	10014	Support assembly (inc. 21 & 22)
24	45006	Caster yoke
25	43022	Sleeve (Caster wheel bearing)
26	04001-37	Bolt
27	04021-07	Hex locknut: 1/2" x 13
28	009275	Flat-free caster assembly
29		
30		
31	481770	Bearing retainer (Caster wheel)
32	481769	Roller bearing (Caster wheel)
33		
34		
35		
36	10015	SPZ Belts
37	10016	Pulley
38	PL	Bolt: M8 x 30mm
39	10117	Taper hub lock
40	04041-07	Washer: 10 x 21

## STM Super Flail 30"

Drawing ref	Part No.	Description
41	10019	Pulley
42	PL	Bolt
43	PL	Shakeproof washer
44	PL	M10 Nyloc nut
45		
46	10022	Skid
47	PL	Bolt M8 x 30mm
48	PL	Nut M8
49	10223	Rubber flap (front) 34" x 5"
50	04021-09	Hex nut: 3/8"
51	04030-04	Spring washer 3/8"
52	10222	Flap retainer
53	PL	Bolt: M8 x 20mm
54	PL	Spring washer: 8mm
55	PL	M10 Flat washer
56		
57		
58	10028	Bolt
59	04050-02	retainer ring
60	10029	Bolt
61	48100-05	Bronze BRG
62	PL	Bolt: M6 x 20mm
63	PL	Spring washer: 6mm
64	10219	Flail head (cowling only)
65		
66	10220	Flail shaft assembly: Twisted flails
67	46081	Idler arm
68	PL	Washer: 3/8 x 2"
69	43028	Eye bolt
70		
71	04041-07	Washer: 24 x 10 x 3
72		
73	43063	Sleeve
74	04001-54	Bolt: 3/8 x 3"
75	10043	Idler pivot
76	10239	Pulley assy inc. bearing & bush
77	10178	Rear flap
78		
79		
80		

### STM Super Flail 30"

Drawing ref	Part No.	Description
81		
82		
83		
84	10221	Flail shaft assy: back to back flails
85	10036	Single back to back flail (48)
86	10037	Single twisted flail (24)
86a	10082	Single twisted flail long
87		
88	PL	Flat washer
89a	12615	Coach bolt / nut
89	10039	Bolt (special)
90	10040	Nut (special)
91	10041	Grass guard
92	10227	Grass guard (slotted)
93	10224	STM decal
94	PL	Bolt: 5/16 x 3/4"
95	PL	Nut: 5/16"
96	10044	bearing (shaft)
97	10471	Taper hub lock
98	10490	Bearing (shaft)
99	PL	Bolt
100		

PL - Purchase Locally