



# Parts and Operators Manual

## STM Humus Super M58 (145) Deck

Ride-on

Version 8 - May 2022



**S T M Company Limited**

Tel: 01789 488450 • Fax: 01789 488032 • Email: [sales@st-mach.com](mailto:sales@st-mach.com) • [www.st-mach.com](http://www.st-mach.com)

## STM Humus Super SM58 deck

### **BELT ADJUSTMENT**

#### Twin rotor drive belts

Remove guard (56), slacken locknut (34) in centre of flat pulley (35), and adjust by use of jack-screw. Re-tighten locknut. (See illustration below).

**Do not over-tension belts!**

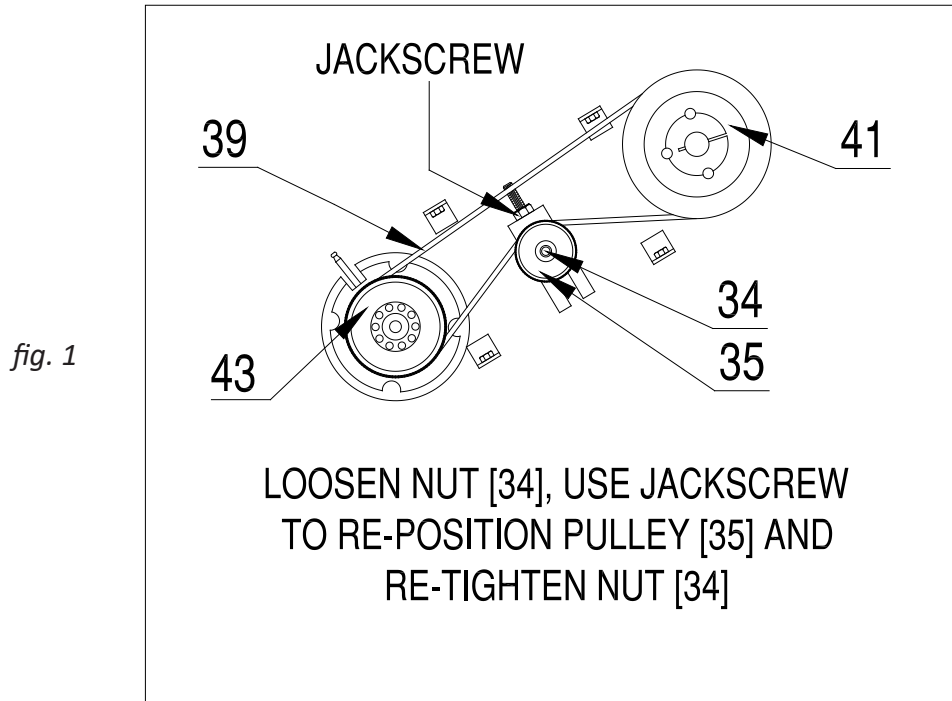

### **BELT REPLACEMENT**

#### Rotor belts

Remove guard (27), slacken adjuster pulley (35) to bottom of slide and remove belts.

**ALWAYS REPLACE THESE BELTS IN PAIRS.**

Adjust belt tension as above and refit guard.

### **LUBRICATION & MAINTENANCE**

#### Gearbox

Check level on yearly service and top up as required.

Remove level plug and fill through plug hole with gear oil EP80/140.

#### Duplex chain (22)- gearbox to top pulley

Lubricate with Open Chain Oil – daily

#### Bearings

Driveshaft (30 & 25) - give 2 or 3 shots with a hand-held grease gun every 500 hours. **DO NOT OVER-GREASE**

## STM Humus Super SM58 deck

### **LUBRICATION & MAINTENANCE [continued]**

*Rotor shaft – 2 or 3 grease shots every 20 hours. Grease nipples accessed at each end. Both ends must be greased. This procedure is vital to the working of the unit.*

*Roller*

*Grease bearings [each end] with 2-3 shots, daily.*

### **VISUAL CHECKS**

*Belt tension:*

*Check after initial ten hours and adjust as necessary. After that, check and adjust every 10 hours.*

*Flaps:*

*Check for damage, cracks or wear and replace as necessary*

*Bolts / Nuts:*

*Check none have loosened [after initial ten hours, then weekly]*

*Cutters:*

*Check condition of cutting teeth units daily and replace if damaged.*

# STM HUMUS 58 sheet 1

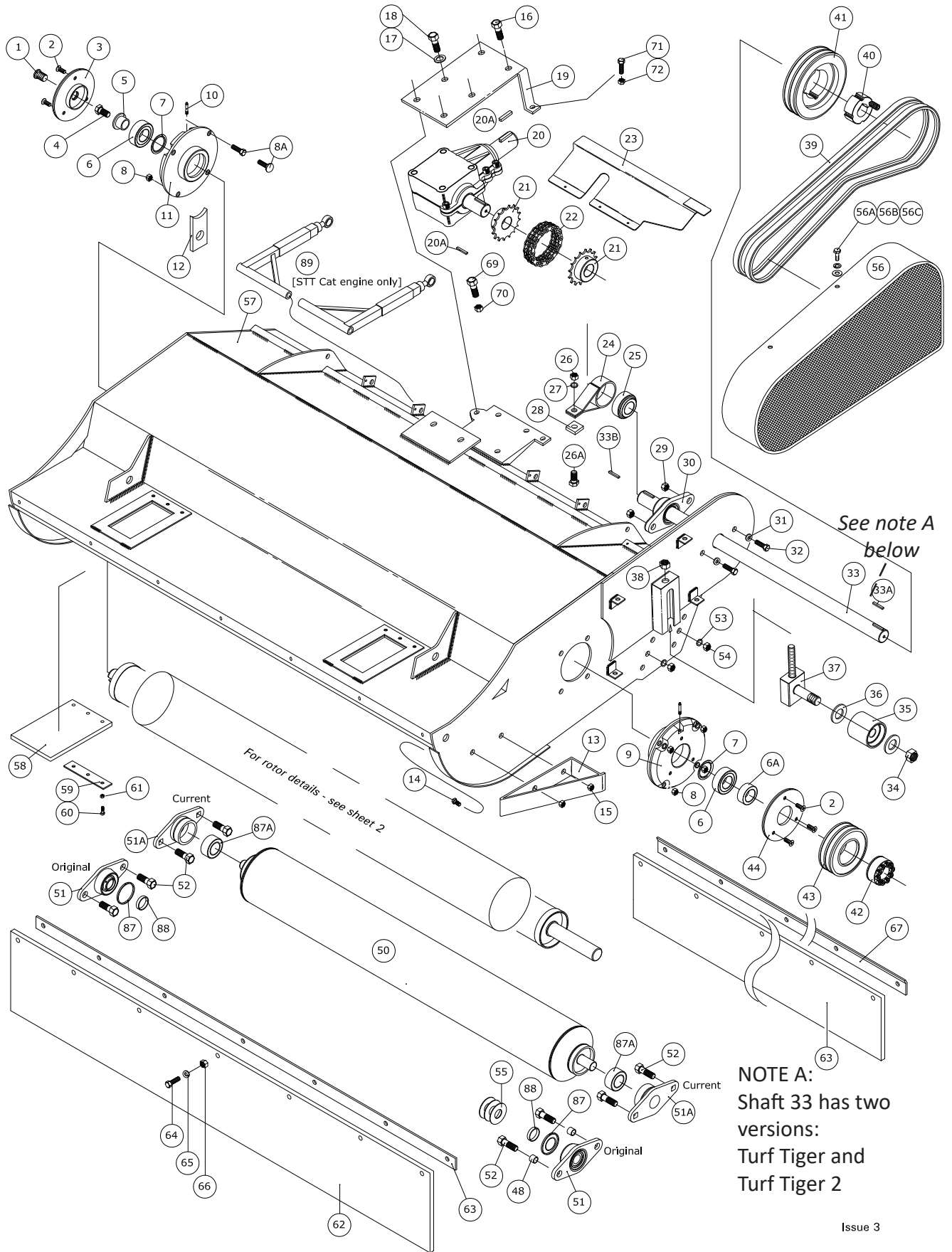

**NOTE A:**  
 Shaft 33 has two versions:  
 Turf Tiger and  
 Turf Tiger 2

Issue 3

# STM HUMUS 58 sheet 2

Safety Cut rotor / Flail options

Castor and extension leg assemblies [STT Kubota version]

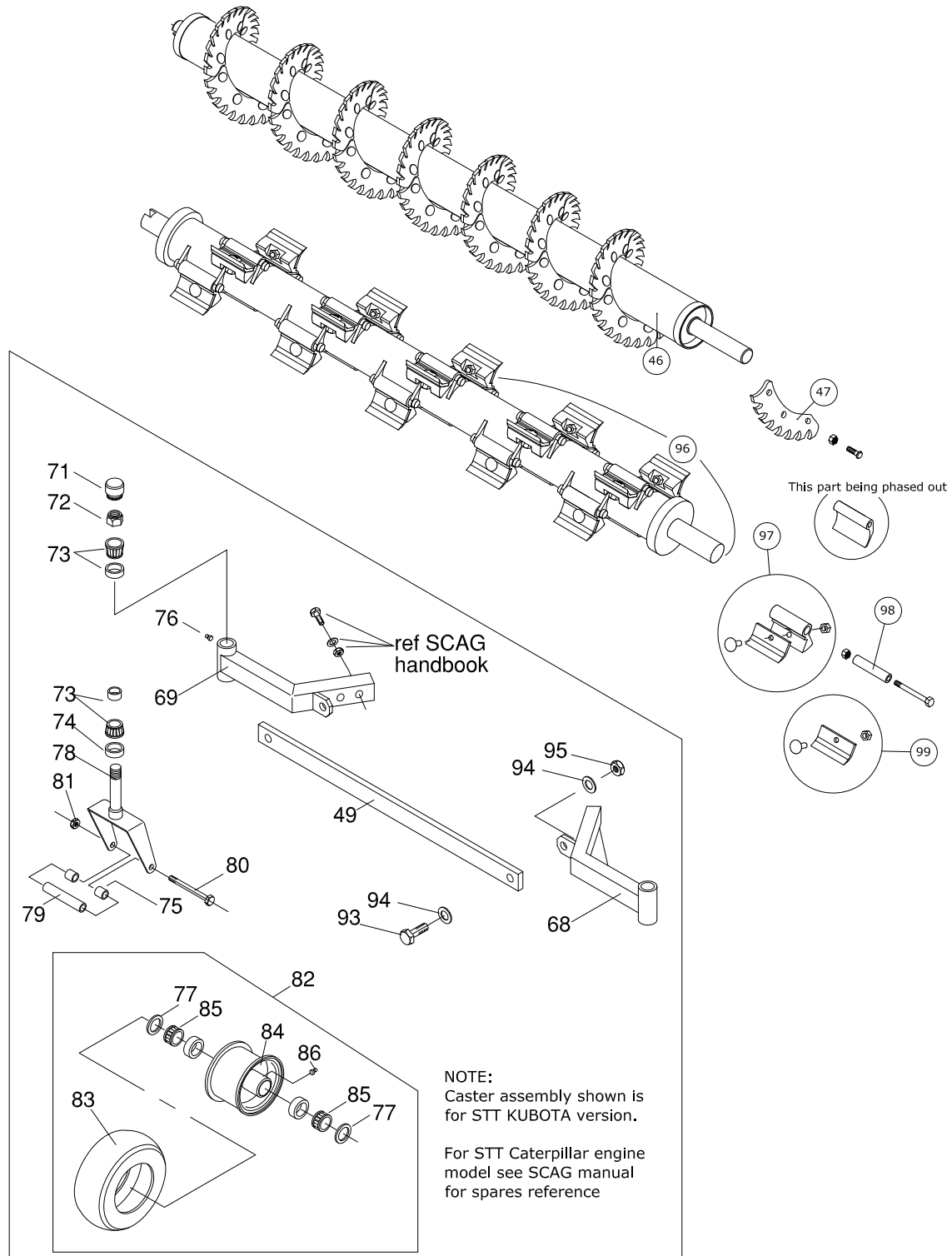

Version 6  
Sept 2021

### STM Humus Super SM58 deck

Drawing ref	Part No.	Description
1	M26391634	Pipe plug
2	M97991015	Flathead screw
3	M26391616	Cover
4	M90912152	Allen Bolt
5	M26391507	Retainer
6	M89022207	Bearing
6A	M26691536	Clamping bush
7	M83002007	Seal
8	M81000335	Nut
8A	M97991605	Bolt
9	M26395184	Bearing casing
10	M97141201	Grease nipple [short]
11	M26395185	Bearing casing
12	10462	Filler plate
13	10463	Deflector
14	PL	Bolt: M10 x 25
15	PL	Nut: M10 Nyloc
16	04017-16	Bolt
17	PL	Washer: M10 flat
18	PL	Bolt: M10 x 25
19	10464	Gearbox Top plate
20	482486	Gearbox
20A	04063-01	Key .25 x .25
21	10453	Coupling assembly: incl. 22
22	10453C	Coupling assembly: chain only
23	10465	Shaft cover
24	10466	Brg Carrier
25	10455	Bearing
26	PL	Nut: M10 Nylon
27	PL	Flat washer M10
28	10467	Damper pad
29	PL	Nut: M8 Nyloc
30	10454	Bearing
31	PL	M8 Flat washer
32	PL	Bolt: M8 x 35
33	10468 TT1	Drive shaft - Turf Tiger
33	10468 TT2	Drive shaft Turf Tiger 2
33A	10468a	Key 7 x 8 x 35
33B	10468b	Key 7 x 8 x 25
34	PL	Nut: M12 Nyloc

### STM Humus Super SM58 deck

Drawing ref	Part No.	Description
35	10264	Tensioner roller
36	10469	Flat washer
37	10470	Adjuster block
38	PL	Nut: M10 Nyloc
39	481496/10577*	Belt [single] - *Serial #1096 on
40	10471	Taper bush
41	10472	Pulley
42	M80013002	Keyless bush
43	10473 / 10576*	Pulley - *Serial # 1096 on
44	M26691537	Bearing cover
45	M97141201	Grease nipple [long]
46	M26695710	Shaft assembly - complete
47	M26695108 / 118*	Blade [blade & fixings] *Serial # 1060 on [Full set: 21 off]
48	10479	Spacer [bearing]
49	10482	Bracing strip
50	M26695722	Roller
51/51A	M89000025/M26695063	Bearing
52	M90933022	Bolt
53	M90127004	Washer
54	M90934005	Nut
55	M26891361	Spacer
56	10475	Guard - Rotor end
56A	PL	Bolt: M6 x 16
56B	PL	Spring washer 6mm
56C	PL	Flat washer 6mm
57	10476	Hood only
58	10477	Rubber flap
59	10478	Retaining strip
60	PL	Screw - M6 x 25
61	PL	Nut: M6 Nyloc
62	M26691726	Front flap
63	M26691724	Retaining strip
64	PL	Bolt: M6 x 25
65	PL	Flat washer
66	PL	Nut: M6 Nyloc
67	M26691725	Rear flap
68	10480	Caster arm extension Op LH
69	10481	Caster arm extension Op RH
70	10482	Crossbar

### STM Humus Super SM58 deck

Drawing ref	Part No.	Description
71	481559	Grease cap
72	04021-20	Nut
73	48668	Bearing set
74	481025	Seal
75	43584	Caster wheel spacer
76	48114-04	Grease nipple
77	482622	Seal
78	45934	Caster yoke
79	43581	Sleeve
80	04001-134	Bolt
81	04021-07	Hex locknut 1/2" x 13
82	482503	Wheel assy
83	481613	Tyre only
84	482625	Rim [inc. grease nipple]
85	482621	Roller bearing assembly
86	48114-04	Grease nipple
87/87A	M81003207/M89022205	Cover [bearing]
88	M83002008	Nilos ring
89	10620	Push arm assy - STT Cat version only
90	PL	Bolt: M10 x 30mm
91	PL	Nut: M8
92	PL	8mm spring washer
93	04001-45	Bolt
94	04041-07	Washer
95	04021-09	Nut
96	M26695274	Rotor & Flail assembly complete
97	M26695365	Single flail with carrier and fixings
98	M85600002	Flail sleeve
99	M-26695367	Single flail tip with nut/bolt

PL \_ Purchase Locally